



Model 363 Control Valve



Figure 1 363 Control Valve

The Model 363 control valve is part of the 360 Series of control Valves.

The Model 363 is a top guided, unbalanced, single port valve that is suitable for either throttling or on/off control of either liquids or gases. Metal to metal seating is standard on Model 363 valves with an option for soft seating.

The standard actuator for the Model 363 control valve is a Dyna-Flo model DFC or DFO linear actuator. These heavy-duty actuators are spring return diaphragm style, and can be used for throttling or on-off service, with or without a valve positioner.

The Model 363 control valves are manufactured to a high level of quality specifications to ensure superior performance and customer satisfaction.

Features

Versatility

Multiple port sizes make the 363 an easy valve to reconfigure when process applications change.

Rugged Design

Available severe service trim and high temperature configurations are well suited to more demanding applications.

Low Temperature Construction Standard

Model 363 valves use LCC body material, and internals rated to -50°F (-46°C).

High Temperature Option

The standard temperature rating of 450°F (232°C) can be extended to 850°F (454°C), with options available for higher temperatures.

Cryogenic Service Option

Optional materials and trim details make the 363 control valve a standard solution for ultra low temperatures.

Full Pressure Drop Capabilities

363 control valves can shut off against inlet pressures equal to the ASME B16.34 rating.

Sour Gas Service Capability

There are standard construction materials that comply with the recommendations of the National Association of Corrosion Engineers (NACE) MR0175.

Shut Off Capability

Shut off options are available from ASME / FCI Class II to Class V.

Flow Characteristic Selections

Equal percentage, linear and quick-opening flow characteristics available.

Easy Maintenance

As with all 360 Series Valves, the 363 can be serviced in line with no special tools required.



Model 363 Control Valve

Specifications

Sizes and Connection Styles

Models 363

Size: 1", 1-1/2", 2"
Rating: ASME 150 / 300 / 600
Connections: RF / RTJ - All Sizes
NPT - 1", 1-1/2" and 2"

Maximum Inlet Temperature and Pressures

Flanged valves consistent with ASME B16.34 Class rating, unless limited by either material pressure or temperature limitations. For Bellows Bonnet valves 150 - 300 Class maximum pressure is 300 Psig at 350°F.

Maximum Pressure Drops

Maximum pressure drop is the same as maximum inlet pressure unless otherwise rated by a specific trim construction. See Table 6.

Standard Shut-off Classifications

In accordance with ASME / FCI 70.2
-Model 363 - Standard Class IV - Metal Seat
-Model 363 - Optional Class V - Metal Seat

See Table 1 for Optional Shut-off capability

Dimensions

Valve and Actuator Assembly Diagram

See Figure 2

Valve and Actuator Assembly Dimensions

See Table 3 and Table 4

Approximate Valve Body and Actuator Weights

See Table 14

Materials

The standard body material is LCC. The standard bonnet material is LF2 or LCC. CF8M (316 SST) is an option. See Table 5 for typical construction materials. See Tables 6 and 7 for trim selections.

Cross-Section of Model 363 Control Valves

See Figure 3

Flow Characteristics

Standard trim is equal percent. Other flow characteristics are available upon request. Model 363 valves normally flow up.

Port Diameters and Maximum Valve Plug Travel

See Table 2

Packing Type

The Standard packing is PTFE V-ring. Live-loaded low emission, graphite and other packing arrangements are available. See Figure 4 for packing diagrams.

Valve Sizing Coefficients

See Tables 7 - 12

Actuator Sizing

Fail Open Actuator

See Table 15

Fail Close Actuator

See Table 16

Trim Style Service Application

See Table 6



Model 363 Control Valve

Table 1

Valve Shut-off Configurations

Valve Model	Size (inch)	Shut Off Capabilities	Valve Plug	Guide	Seat
363	1, 1-1/2 & 2	Class IV	Unbalanced	Top	Metal
	1, 1-1/2 & 2	Optional Class V	Unbalanced	Top	Metal

Table 2

Model 363
Port Diameters, Valve Plug Travel, Stem
and Yoke Boss Diameter

Valve Size	Port Diameter		Max Valve Plug Travel	
	Inch	mm	Inch	mm
1", 1-1/2" & 2" Dyna-Form	1/4	6	3/4	19
1" Dyna-Form	3/8	10	3/4	19
1" Dyna-Form	1/2	13	3/4	19
1" Dyna-Form	3/4	19	3/4	19
1" Full Port	1	25	3/4	19
1-1/2" Full Port	1-1/2	38	3/4	19
1-1/2" Reduced Port	1	25	3/4	19
1-1/2" Dyna-Form	3/8	10	3/4	19
1-1/2" Dyna-Form	1/2	13	3/4	19
1-1/2" Dyna-Form	3/4	19	3/4	19
2" Full Port	2	51	1-1/8	29
2" Reduced Port	1	25	3/4	19
2" Dyna-Form	1/4	6	3/4	19
2" Dyna-Form	3/8	10	3/4	19
2" Dyna-Form	1/2	13	3/4	19
2" Dyna-Form	3/4	19	3/4	19



Model 363 Control Valve

Table

Model 363 Port Diameters, Valve Travel and Mounting Connection

Valve Size inch	Port Diameter inch (mm)			Max Valve Travel inch (mm)	Valve Stem and Mounting Connection Diameter inch (mm)			
	Equal Percentage ¹	Linear	Quick Open		Standard		Optional	
					Stem	Yoke Boss	Stem	Yoke Boss
1	3/16 (4.8)	1 (25.4)	1 (25.4)	3/4 (19.1)	3/8 (9.5)	2-1/8 (54)	1/2 (12.7)	2-13/16 (71)
	1/4 (6.4) ²							
	3/8 (9.5)							
	1/2 (12.7)							
	3/4 (19.1)							
	1 (25.4)							
1-1/2	3/16 (4.8)	1-1/2 (38.1)	1-1/2 (38.1)	3/4 (19.1)	3/8 (9.6)	2-1/8 (54)	1/2 (12.7)	2-13/16 (71)
	1/4 (6.4) ²							
	3/8 (9.5)							
	1/2 (12.7)							
	3/4 (19.1)							
	1 (25.4)							
1-1/2 (38.1)								
2	3/16 (4.8)	2 (50.8)	2 (50.8)	1-1/8 (29)	1/2 (12.7)	2-13/16 (71)	3/4 (19.1)	3-9/16 (90)
	1/4 (6.4) ²							
	3/8 (9.5)							
	1/2 (12.7)							
	3/4 (19.1)							
	1 (25.4)							
	1-1/2 (38.1)							
	2 (50.8)							

1 - Port Diameters 1/4 - 3/4 inch (6.4 - 19.1 mm) use Dyna-Form valve plugs.

2 - Also available in 3-flute Dyna-Flute valve plugs.



Model 363 Control Valve

Table 3

1" to 2" Regular Bonnet Valve Assembly with Actuator Envelope Dimensions
 Inches (mm)
 (Refer to Figure 2)

Valve Size (inch)	End Connection	Actuator Size	A	B	C	D		E
						DFO	DFC	
1	ASME 150	1069	7.25 (184)	2.38 (60)	5.00 (127)	24.6 (625)	27.60 (700)	13.12 (333)
	ASME 300	1069	7.75 (197)	2.38 (60)	5.00 (127)	24.6 (625)	27.60 (700)	13.12 (333)
	ASME 600	1069	8.25 (210)	2.38 (60)	5.00 (127)	24.6 (625)	27.60 (700)	13.12 (333)
	NPT	1069	8.25 (210)	2.38 (60)	5.00 (127)	24.6 (625)	27.60 (700)	13.12 (333)
1-1/2	ASME 150	1069	8.75 (222)	2.81 (71)	4.88 (124)	24.48 (622)	27.48 (697)	13.12 (333)
	ASME 300	1069	9.25 (235)	2.81 (71)	4.88 (124)	24.48 (622)	27.48 (697)	13.12 (333)
	ASME 600	1069	9.75 (248)	2.81 (71)	4.88 (124)	24.48 (622)	27.48 (697)	13.12 (333)
	NPT	1069	9.88 (251)	2.81 (71)	4.88 (124)	24.48 (622)	27.48 (697)	13.12 (333)
2	ASME 150	2069	10.00 (254)	3.06 (78)	6.50 (165)	28.10 (714)	29.88 (759)	13.12 (333)
	ASME 150	2105	10.00 (254)	3.06 (78)	6.50 (165)	32.44 (824)	36.75 (933)	16.00 (406)
	ASME 300	2069	10.50 (267)	3.06 (78)	6.50 (165)	28.10 (714)	29.88 (759)	13.12 (333)
	ASME 300	2105	10.50 (267)	3.06 (78)	6.50 (165)	32.44 (824)	36.75 (933)	16.00 (406)
	ASME 600	2069	11.25 (286)	3.06 (78)	6.50 (165)	28.10 (714)	29.88 (759)	13.12 (333)
	ASME 600	2105	11.25 (286)	3.06 (78)	6.50 (165)	32.44 (824)	36.75 (933)	16.00 (406)
	ASME 600	2156	11.25 (286)	3.06 (78)	6.50 (165)	32.44 (824)	36.75 (933)	18.62 (473)
	NPT	2069	11.25 (286)	3.06 (78)	6.50 (165)	28.10 (714)	29.88 (759)	13.12 (333)
	NPT	2105	11.25 (286)	3.06 (78)	6.50 (165)	32.44 (824)	36.75 (933)	16.00 (406)
	NPT	2156	11.25 (286)	3.06 (78)	6.50 (165)	32.44 (824)	36.75 (933)	18.62 (473)

Table 4

1" to 2" Extension Bonnet Dimensions (Styles 1 and 2)
 (Refer to Figure 2)

Valve Size (inch)	C			
	Style 1		Style 2	
	Stem Diameter inch (mm)			
	3/8 (9.5)	1/2 (12.7)	3/8 (9.5)	1/2 (12.7)
1	8.38 (213)	9.88 (251)	11.94 (303)	12.56 (319)
1.5	8.25 (210)	9.75 (248)	11.81 (300)	12.44 (316)
2	---	10.50 (267)	---	18.31 (465)

Valve Size & (Actuator Model)	D							
	Style 1				Style 2			
	Stem Diameter inch (mm)							
	3/8 (9.5)		1/2 (12.7)		3/8 (9.5)		1/2 (12.7)	
	DFC	DFO	DFC	DFO	DFC	DFO	DFC	DFO
1 inch (1069)	30.98(787)	27.98(711)	32.48(825)	29.48(749)	34.54(877)	31.54(801)	35.16(893)	32.16(817)
1.5 inch (1069)	30.85(784)	27.85(707)	32.35(822)	29.35(745)	34.41(874)	31.41(798)	35.04(890)	32.04(814)
2 inch (2069)	---	---	33.90(861)	32.10(815)	---	---	41.71(1059)	39.91(1014)
2 inch (2105)	---	---	40.80(1036)	36.40(925)	---	---	48.61(1235)	44.21(1123)
2 inch (2156)	---	---	39.90(1013)	36.30(922)	---	---	47.71(1212)	44.11(1120)



Model 363 Control Valve

Table 5

1" to 2" Bellows Bonnet Dimensions

(Refer to Figure 2)

Valve Size & (Actuator Model)	C		D	
	Stem Diameter inch (mm)	DFC	DFO	DFO
	1/2 (12.7)	Inch (mm)		Inch (mm)
1 inch (2069)	12.62 (321)	36.02 (915)		34.22 (869)
1.5 inch (2069)	12.50 (317)	35.90 (912)		34.10 (866)
2 inch (2069)	15.12 (384)	38.52 (978)		36.72 (933)
2 inch (2105)	15.12 (384)	45.42 (1,154)		41.02 (1,042)
2 inch (2156)	15.12 (384)	44.52 (1,131)		40.92 (1,039)

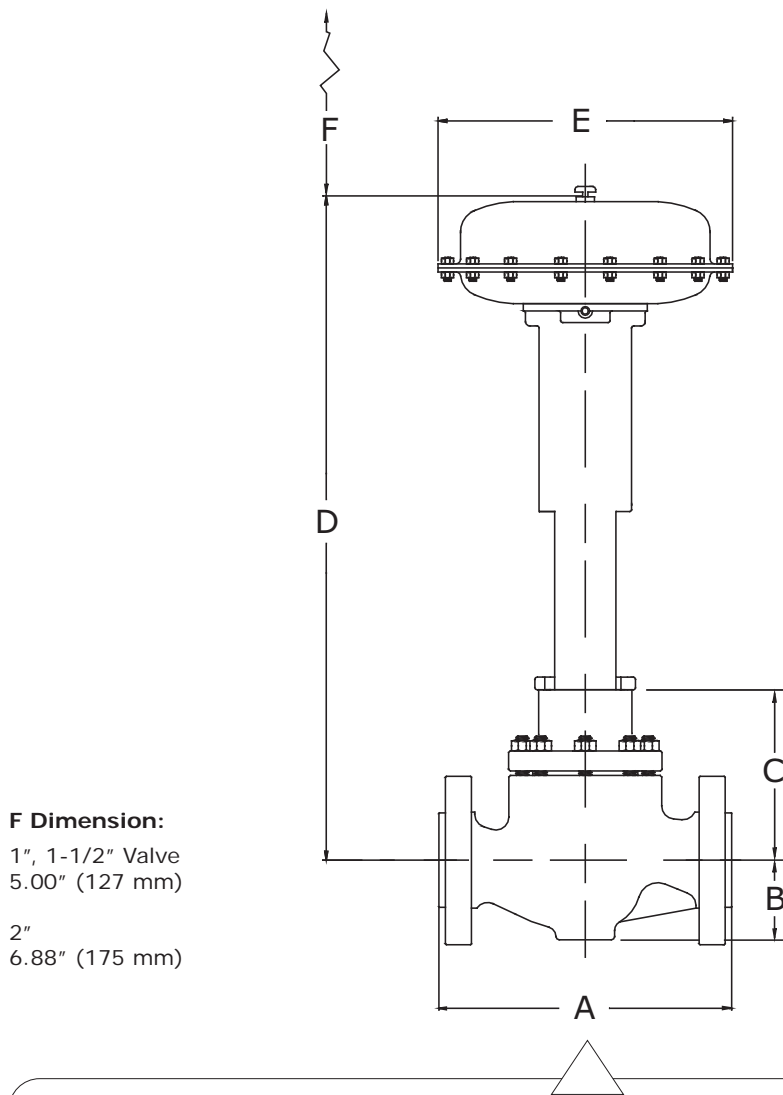

F Dimension:
 1", 1-1/2" Valve
 5.00" (127 mm)
 2"
 6.88" (175 mm)

Figure 2 Valve Assembly with DFC Actuator Outline Dimensions



Model 363 Control Valve

Table 4

Typical Construction Materials

Part Description	Standard Construction	NACE Construction
BODY	ASTM (A352 LCC), ASTM (A351 CF8M)	SA352 Gr LCC
BONNET	SA350 LF2 / A352 LCC	SA350 LF2 / A352 LCC
	SA351 Gr CF8M*	SA351 Gr CF8M
BAFFLE	S31600	S31600
BELLOWS BONNET	S31603 / N06625 (INCONEL 625)	S31600 / N06625 (INCONEL 625)
PACKING BOX RING	S31600	S31600
PACKING SPRING	S30400	N/A
SPRING WASHERS	N07718 (INCONEL 718)	N07718 (INCONEL 718)
O-RING	HNBR	HNBR
LANTERN RING	-	S31600
SPECIAL WASHER	S30400	N/A
GUIDE BUSHING	CARBON GRAPHITE	N/A
V-RING PACKING SET	PTFE	PTFE (Double)
PACKING RIBBON	GRAPHITE	GRAPHITE
PACKING FILAMENT	GRAPHITE	GRAPHITE
PACKING FOLLOWER	S31600	S31600
PACKING FLANGE	1020 / Zinc	1020 / ZINC
UPPER WIPER	FELT	FELT
LOWER WIPER	TEFLON	TEFLON
	S41600 PLUG / S20910 STEM	N/A
VALVE PLUG / STEM ASS'Y	S31600 PLUG / S20910 STEM	S31600 PLUG / S20910 STEM
	S31600-CoCr-A PLUG / S20910 STEM	S31600-CoCr-A PLUG / 20910 STEM
VALVE PLUG ADAPTER	S31600	S31600
PIN	STEEL	STEEL
	S41600	N/A
SEAT RING	S31600-CoCr-A	S31600-CoCr-A
	S31600	S31600
SEAT RING RETAINER	SA351 Gr CF8M*	SA351 Gr CF8M*
	S31600-CoCr-A	S31600-CoCr-A
RETAINER BUSHING	S17400 DH 1150	S17400 DH 1150
PACKING FLANGE	CARBON STEEL-PLATED	CARBON STEEL-PLATED
PACKING NUT	SA-194 2H	SA-194 2H
PACKING STUD	SA-193 B7	SA-193 B7
BONNET NUT	SA-194 2H	SA-194 2HM
	SA-193 B7	SA-193 B7M
BONNET STUD	S17400 DH 1150* (600 ASME Class)	S17400 DH 1150* (600 ASME Class)
GASKETS	GRAPHITE / S31600	GRAPHITE / S31600
SPIRAL WOUND GASKET	S30400 / GRAPHITE	S30400 / GRAPHITE
SHIM	S31600	S31600
STEM SET SCREW	SST	SST
STEM SCREW RETAINER	SST	SST

* Optional construction material

See tables for service limits



Model 363 Control Valve

Figure 3 Cross-section of 363 Series Control Valve with Trim Details

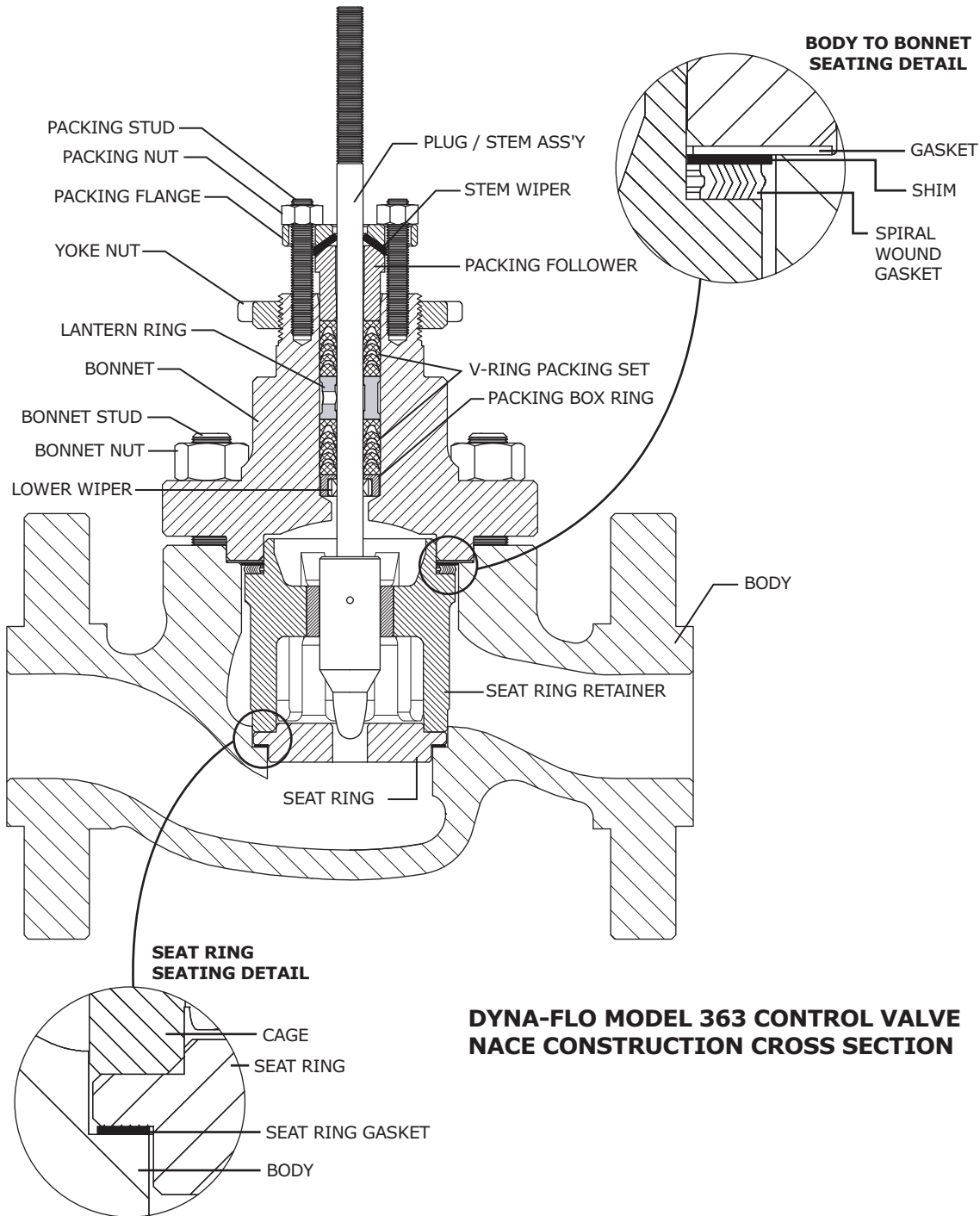

DYNA-FLO MODEL 363 CONTROL VALVE NACE CONSTRUCTION CROSS SECTION



Model 363 Control Valve

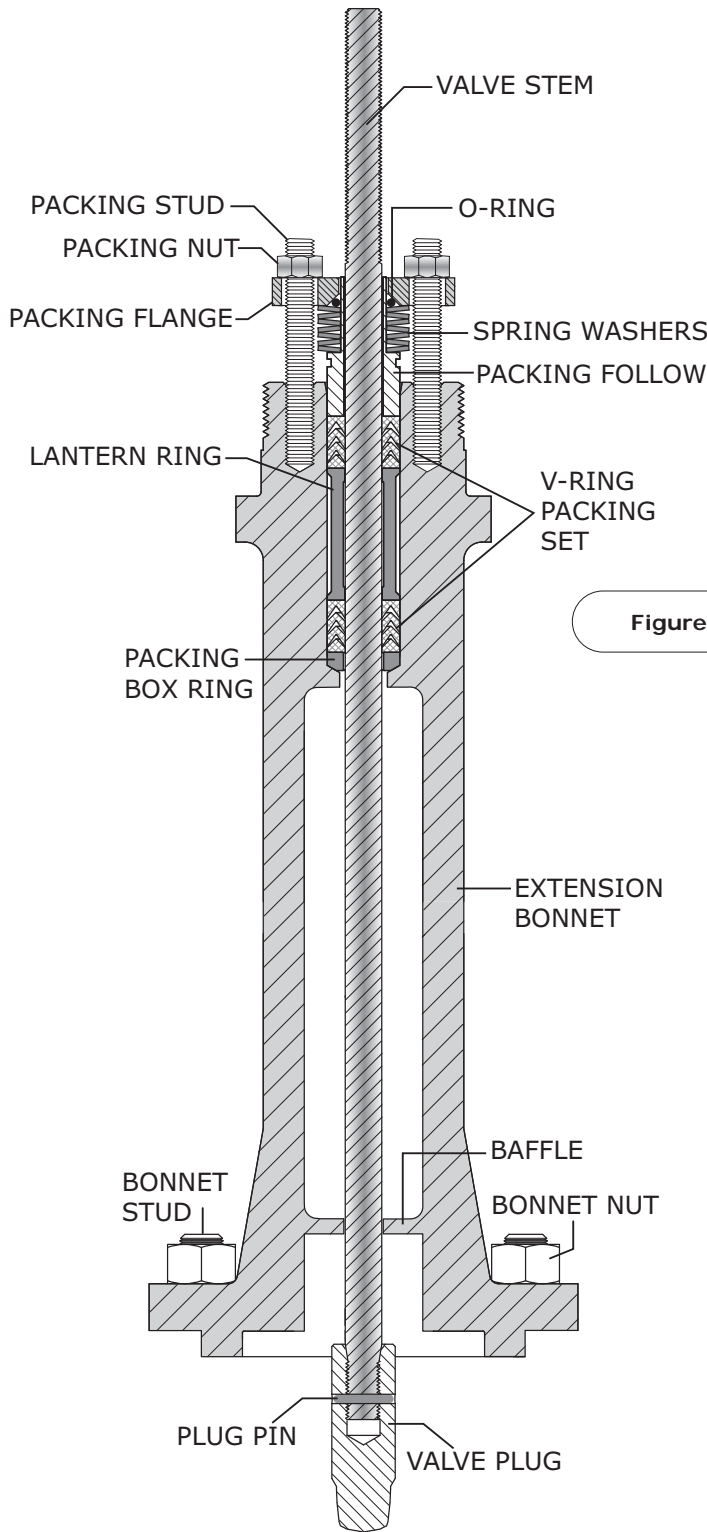
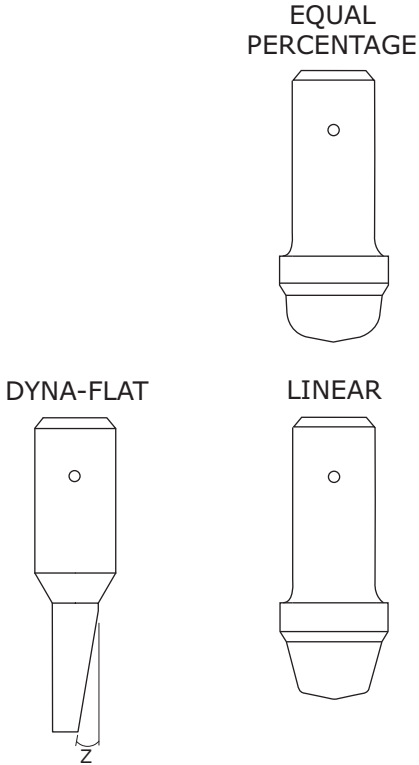

Figure 4 Model 363 Extension Bonnet Cross Section

Figure 5 Valve Plug Style Diagrams

*NOTE - plug styles continued on Page 10.





Model 363 Control Valve

Figure 6 Model 363 Bellows Bonnet Cross Section

Figure 7 Valve Plug Style Diagrams

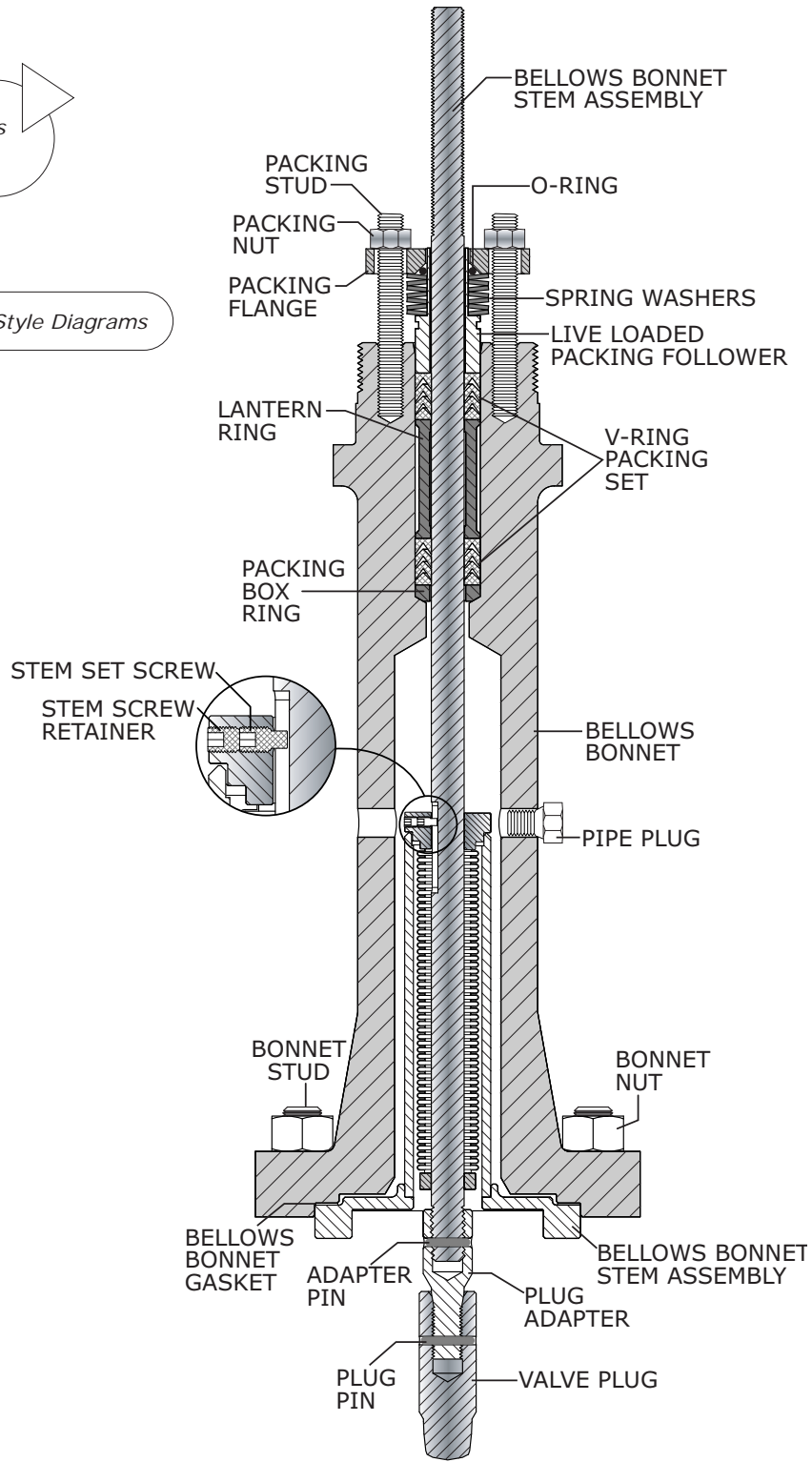
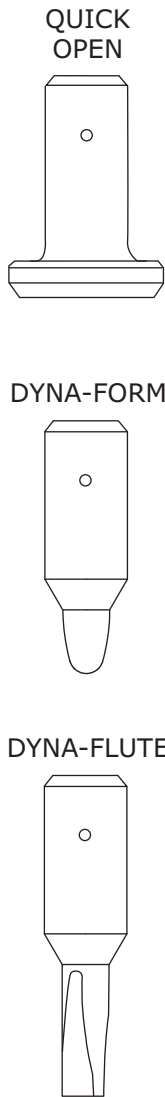



Model 363 Control Valve

Figure 8 Model 363 Packing Style Diagrams

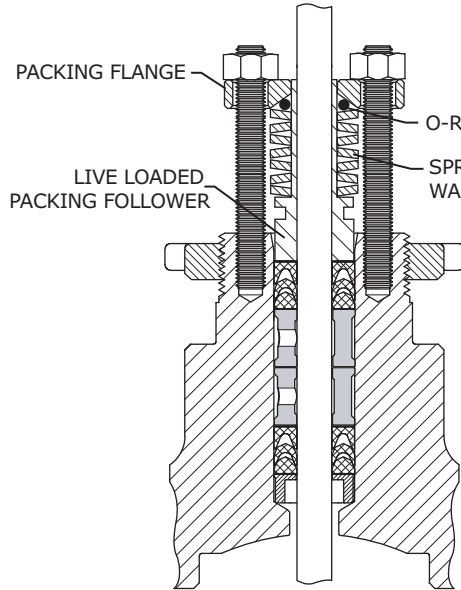

TYPICAL LIVE LOADED PACKING WITH PTFE V-RING PACKING SETS

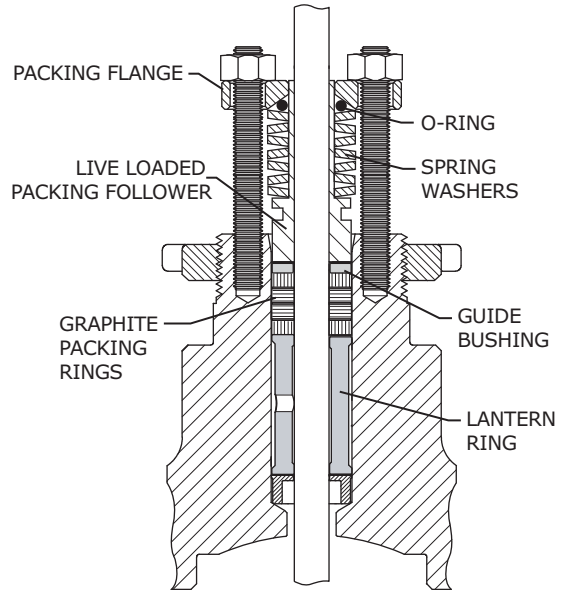

TYPICAL LIVE LOADED PACKING WITH GRAPHITE PACKING RINGS

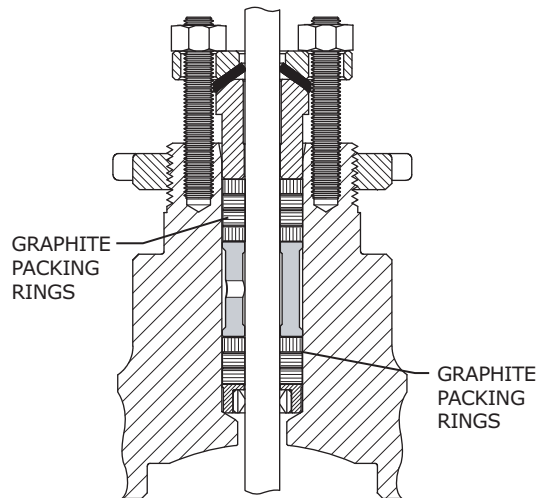

STANDARD HIGH TEMPERATURE PACKING DIAGRAM

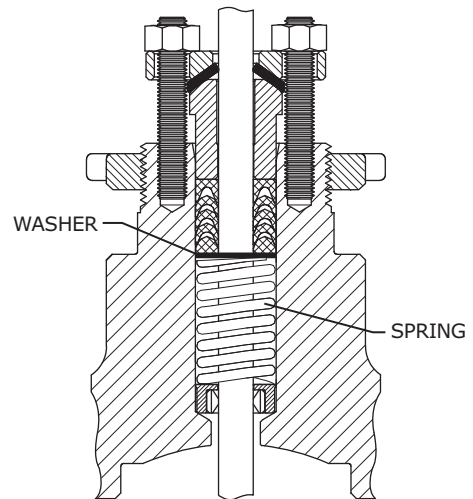

STANDARD SINGLE PTFE PACKING DIAGRAM



Model 363 Control Valve

Table 5

Trim Options

Trim Spec	Valve Plug	Stem	Seat Ring Retainer	Seat Ring	Guide Bushing	Service
Z1	S41600 Hardened	S20910	CF8M	S41600	S17400 DH 1150	Standard
Z2	31600	S20910	CF8M	316 SST	S17400 DH 1150	NACE
Z3	S31600 w/ CoCr-A Hardfacing Seat	S20910	CF8M	316 SST w/Alloy 6 Hardfacing Seat	S17400 DH 1150	NACE / Errosive
Z4*	S31600 w/ CoCr-A Hardfacing Seat and Guide	S20910	CF8M	S31600 w/ CoCr-A Hardfacing Seat and Bore	CoCr-A	NACE / High Temperature / Errosive
Z5	S31600 / Tungsten Carbide	S20910	CF8M	S31600 w/ CoCr-A Hardfacing Seat and Bore	S17400 DH 1150	NACE

* **NOTE:** Z4 Trim for 1-12" & 2" Bodies with 1", 1-1/2" & 2" Ports have a S31600/CoCr-A Seat Ring that is not Hardfacing

Table 6

Trim Style Service Application

Trim Spec	Body Material	Shut Off Class	Maximum Shutoff Pressure Drop @ 100°F ⁽¹⁾ Psig (kPag)	Minimum Temperature °F (°C)	Maximum Temperature °F (°C)
Z1	LCC	VI	1,500 (10,342)	-20 (-29)	650 (343)
	LCC	VI	1,500 (10,342)	-20 (-29)	650 (343)
Z2	LCC	IV or V	1,500 (10,342)	-50 (-45)	650 (343)
	LCC	IV or V	1,500 (10,342)	-50 (-45)	450 (232)
	CF8M	IV or V	1,500 (10,342)	-150 (-101)	700 (371)
Z3 / Z4	LCC	IV or V	1,500 (10,342)	-50 (-45)	650 (343)
	CF8M	IV or V	1,500 (10,342)	-150 (-101)	700 (371)

⁽¹⁾ Actuator sizing is also a contributing factor for Maximum Shutoff.



Model 363 Control Valve

Table 7

Models 363 Valve Sizing Coefficients, Equal Percentage Trim

Valve Size	Port	Travel	Co-efficient	Percentage of Valve Travel									
Inches	Inches (mm)	Inches (mm)		10%	20%	30%	40%	50%	60%	70%	80%	90%	100%
Equal Percentage													
1	1 (25.4)	3/4 (19.1)	C_v	0.80	1.25	1.80	2.50	3.61	5.26	7.60	10.5	12.5	13.1
			X_T	0.642	0.635	0.598	0.581	0.582	0.594	0.647	0.676	0.755	0.885
			F_L	0.95	0.95	0.95	0.95	0.95	0.95	0.95	0.95	0.95	0.95
1-1/2	1-1/2 (38.1)	3/4 (19.1)	C_v	0.793	1.22	1.90	2.95	4.26	6.44	9.82	16.3	22.0	28.0
			X_T	0.725	0.674	0.732	0.644	0.587	0.556	0.598	0.652	0.775	0.839
			F_L	0.96	0.96	0.96	0.96	0.96	0.96	0.96	0.96	0.96	0.96
1-1/2	1 (25.4)	3/4 (19.1)	C_v	0.766	1.21	1.76	2.56	3.65	5.52	8.28	12.0	15.0	17.1
			X_T	0.652	0.617	0.600	0.603	0.560	0.533	0.516	0.574	0.701	0.860
			F_L	0.98	0.98	0.98	0.98	0.98	0.98	0.98	0.98	0.98	0.98
2	2 (50.8)	1-1/8 (28.6)	C_v	1.64	2.60	4.28	6.60	11.0	20.5	32.7	44.5	49.8	53.5
			X_T	0.653	0.580	0.521	0.557	0.550	0.527	0.652	0.798	0.901	0.898
			F_L	0.95	0.95	0.95	0.95	0.95	0.95	0.95	0.95	0.95	0.95
2	1 (25.4)	3/4 (19.1)	C_v	1.01	1.49	2.03	2.76	3.88	5.56	8.15	11.5	14.1	15.7
			X_T	0.597	0.613	0.600	0.576	0.569	0.552	0.521	0.543	0.669	0.902
			F_L	0.91	0.91	0.91	0.91	0.91	0.91	0.91	0.91	0.91	0.91

Relationships of note: $C_1 = 39.76 \sqrt{X_T}$ $C_G = C_V C_1$ $K_M = F_L^2$

Table 8

Models 363 Valve Sizing Coefficients, Quick Opening Trim

Valve Size	Port	Travel	Co-efficient	Percentage of Valve Travel									
Inches	Inches (mm)	Inches (mm)		10%	20%	30%	40%	50%	60%	70%	80%	90%	100%
Quick Opening Plug													
1	1 (25.4)	3/4 (19.1)	C_v	4.35	10.1	13.9	15.5	16.0	16.6	16.7	16.8	16.9	16.9
			X_T	0.400	0.450	0.522	0.537	0.535	0.510	0.500	0.500	0.490	0.494
			F_L	0.93	0.93	0.93	0.93	0.93	0.93	0.93	0.93	0.93	0.93
1-1/2	1-1/2 (38.1)	3/4 (19.1)	C_v	5.62	11.8	20.5	27.2	30.5	32.2	33.1	33.5	34.0	34.1
			X_T	0.621	0.734	0.726	0.812	0.841	0.855	0.860	0.860	0.853	0.848
			F_L	0.95	0.95	0.95	0.95	0.95	0.95	0.95	0.95	0.95	0.95
1-1/2	1 (25.4)	3/4 (19.1)	C_v	4.15	8.93	14.5	17.2	18.1	18.6	18.8	19.0	19.1	19.3
			X_T	0.615	0.790	0.792	0.904	0.925	0.925	0.922	0.915	0.905	0.879
			F_L	0.90	0.90	0.90	0.90	0.90	0.90	0.90	0.90	0.90	0.90
2	2 (50.8)	1-1/8 (29)	C_v	13.0	30.2	44.2	52.3	56.1	57.6	58.4	58.4	58.6	58.6
			X_T	0.546	0.662	0.765	0.811	0.816	0.831	0.831	0.835	0.832	0.832
			F_L	0.93	0.93	0.93	0.93	0.93	0.93	0.93	0.93	0.93	0.93
2	1 (25.4)	3/4 (19.1)	C_v	4.35	9.76	14.7	16.5	17.2	17.5	17.5	17.5	17.8	17.8
			X_T	0.522	0.595	0.695	0.876	0.935	0.942	0.958	0.958	0.941	0.941
			F_L	0.85	0.85	0.85	0.85	0.85	0.85	0.85	0.85	0.85	0.85

Relationships of note: $C_1 = 39.76 \sqrt{X_T}$ $C_G = C_V C_1$ $K_M = F_L^2$



Model 363 Control Valve

Table 09

Models 363 Valve Sizing Coefficients, Linear Trim

Valve Size	Port	Travel	Co-efficient	Percentage of Valve Travel																				
				10%	20%	30%	40%	50%	60%	70%	80%	90%	100%											
Inches	Inches (mm)	Inches (mm)																						
Linear Plug																								
1	1 (25.4)	3/4 (19.1)	C _v	2.20	3.86	5.27	6.55	8.21	9.80	11.1	12.0	13.1	13.5											
			X _T	0.636	0.600	0.636	0.632	0.636	0.630	0.635	0.680	0.768	0.832											
			F _L	0.95	0.95	0.95	0.95	0.95	0.95	0.95	0.95	0.95	0.95	0.95	0.95									
1-1/2	1-1/2 (38.1)	3/4 (19.1)	C _v	4.00	7.52	11.1	14.6	18.6	22.5	25.6	29.0	31.1	31.9											
			X _T	0.634	0.650	0.656	0.690	0.672	0.672	0.695	0.702	0.756	0.817											
			F _L	0.95	0.95	0.95	0.95	0.95	0.95	0.95	0.95	0.95	0.95	0.95	0.95									
1-1/2	1 (25.4)	3/4 (19.1)	C _v	1.95	3.40	4.95	6.10	7.7	9.2	10.8	13.0	15.0	16.6											
			X _T	0.497	0.577	0.600	0.690	0.651	0.654	0.636	0.624	0.718	0.795											
			F _L	0.95	0.95	0.95	0.95	0.95	0.95	0.95	0.95	0.95	0.95	0.95	0.95									
2	2 (50.8)	1-1/4 (29)	C _v	6.06	11.7	18.0	24.0	30.0	36.2	42.7	49.7	52.0	52.2											
			X _T	0.560	0.642	0.655	0.674	0.700	0.723	0.776	0.771	0.860	0.922											
			F _L	0.94	0.94	0.94	0.94	0.94	0.94	0.94	0.94	0.94	0.94	0.94	0.94									
2	1 (25.4)	3/4 (19.1)	C _v	1.87	3.40	4.95	6.47	8.04	9.65	11.22	12.76	14.34	15.5											
			X _T	0.607	0.592	0.596	0.622	0.620	0.625	0.641	0.632	0.750	0.909											
			F _L	0.94	0.94	0.94	0.94	0.94	0.94	0.94	0.94	0.94	0.94	0.94	0.94									

Relationships of note: $C_1 = 39.76\sqrt{X_T}$ $C_G = C_V C_1$ $K_M = F_L^2$

Table 10

Models 363 Valve Sizing Coefficients, Dyna-Flute Trim

Valve Size	Port	Travel	Co-efficient	Percentage of Valve Travel																				
				10%	20%	30%	40%	50%	60%	70%	80%	90%	100%											
Inches	Inches (mm)	Inches (mm)																						
Dyna-Flute Plug - Flat Angle 1°55' (Refer to Figure Key Z)																								
1, 1-1/2 & 2	3/16 (4.8)	3/4 (19.1)	C _v	0.015	0.020	0.022	0.029	0.034	0.040	0.048	0.056	0.065	0.075											
			X _T	0.963	0.888	0.905	0.947	0.942	0.928	0.949	0.947	0.918	0.934											
			F _L	0.89	0.89	0.89	0.89	0.89	0.89	0.89	0.89	0.89	0.89	0.89	0.89									
Dyna-Flute Plug - Flat Angle 3°25' (Refer to Figure Key Z)																								
1, 1-1/2 & 2	3/16 (4.8)	3/4 (19.1)	C _v	0.015	0.025	0.038	0.052	0.070	0.088	0.106	0.125	0.153	0.180											
			X _T	0.707	0.696	0.687	0.700	0.675	0.679	0.680	0.680	0.681	0.681											
			F _L	0.84	0.84	0.84	0.84	0.84	0.84	0.84	0.84	0.84	0.84	0.84	0.84									

Relationships of note: $C_1 = 39.76\sqrt{X_T}$ $C_G = C_V C_1$ $K_M = F_L^2$



Model 363 Control Valve

Table 11

Models 363 Valve Sizing Coefficients, Dyna-Form Trim

Valve Size	Port	Travel	Co-efficient	Percentage of Valve Travel									
Inches	Inches (mm)	Inches (mm)		10%	20%	30%	40%	50%	60%	70%	80%	90%	100%
Dyna-Form Plug													
1, 1-1/2 or 2	1/4 (6)	3/4 (19)	C_v	0.088	0.124	0.175	0.236	0.327	0.464	0.641	0.881	1.22	1.52
			X_T	0.771	0.717	0.658	0.645	0.620	0.585	0.596	0.596	0.603	0.647
			F_L	0.88	0.88	0.88	0.88	0.88	0.88	0.88	0.88	0.88	0.88
1	3/8 (10)	3/4 (19)	C_v	0.129	0.199	0.308	0.448	0.62	0.882	1.29	1.8	2.43	3.07
			X_T	0.747	0.663	0.641	0.593	0.569	0.568	0.560	0.571	0.624	0.662
			F_L	0.89	0.89	0.89	0.89	0.89	0.89	0.89	0.89	0.89	0.89
1	1/2 (13)	3/4 (19)	C_v	0.189	0.319	0.492	0.735	1.08	1.53	2.12	2.99	4.17	4.91
			X_T	0.728	0.639	0.628	0.591	0.573	0.585	0.600	0.618	0.645	0.803
			F_L	0.93	0.93	0.93	0.93	0.93	0.93	0.93	0.93	0.93	0.93
1	3/4 (19)	3/4 (19)	C_v	0.374	0.622	0.965	1.47	2.17	3.15	4.57	6.52	8.17	8.84
			X_T	0.687	0.614	0.588	0.560	0.571	0.596	0.603	0.624	0.750	0.919
			F_L	0.97	0.97	0.97	0.97	0.97	0.97	0.97	0.97	0.97	0.97
1-1/2 & 2	3/8 (10)	3/4 (19)	C_v	0.121	0.19	0.302	0.435	0.600	0.864	1.26	1.80	2.56	3.20
			X_T	0.915	0.763	0.699	0.657	0.640	0.624	0.608	0.596	0.594	0.648
			F_L	0.84	0.84	0.84	0.84	0.84	0.84	0.84	0.84	0.84	0.84
1-1/2 & 2	1/2 (13)	3/4 (19)	C_v	0.199	0.323	0.503	0.735	1.07	1.54	2.14	3.08	4.36	5.18
			X_T	0.748	0.686	0.640	0.617	0.627	0.602	0.607	0.607	0.573	0.705
			F_L	0.91	0.91	0.91	0.91	0.91	0.91	0.91	0.91	0.91	0.91
1-1/2 & 2	3/4 (19)	3/4 (19)	C_v	0.434	0.683	1.00	1.49	2.21	3.18	4.61	6.73	8.88	10.2
			X_T	0.747	0.625	0.636	0.596	0.578	0.603	0.593	0.591	0.680	0.796
			F_L	0.92	0.92	0.92	0.92	0.92	0.92	0.92	0.92	0.92	0.92

Relationships of note: $C_1 = 39.76\sqrt{X_T}$ $C_G = C_V C_1$ $K_M = F_L^2$

Table 12

Models 363 Valve Sizing Coefficients, Dyna-Flute Trim

Valve Size	Port	Travel	Co-efficient	Percentage of Valve Travel									
Inches	Inches (mm)	Inches (mm)		10%	20%	30%	40%	50%	60%	70%	80%	90%	100%
Dyna-Flute Plug													
1, 1-1/2 & 2	1/4 (6.4) 1 Flute	3/4 (19.1)	C_v	0.038	0.046	0.055	0.072	0.094	0.122	0.160	0.210	0.277	0.354
			X_T	0.776	0.732	0.688	0.651	0.640	0.633	0.635	0.632	0.630	0.656
			F_L	0.86	0.86	0.86	0.86	0.86	0.86	0.86	0.86	0.86	0.86
1, 1-1/2 & 2	1/4 (6.4) 3 Flutes	3/4 (19.1)	C_v	0.056	0.073	0.100	0.145	0.215	0.310	0.432	0.586	0.800	1.06
			X_T	0.690	0.646	0.638	0.625	0.600	0.585	0.595	0.612	0.620	0.622
			F_L	0.90	0.90	0.90	0.90	0.90	0.90	0.90	0.90	0.90	0.90

Relationships of note: $C_1 = 39.76\sqrt{X_T}$ $C_G = C_V C_1$ $K_M = F_L^2$



Model 363 Control Valve

Table 13

Models 363 Valve Sizing Coefficients (C_v), Bellows Bonnet with Live Loaded Packing

Valve Size	Bellows Travel Inch (mm)	Full Size Trim			Restricted Trim		
		Equal Percentage	Linear	Quick Open	Equal Percentage	Linear	Quick Open
1	0.56 (14.2)	9.15	11.6	16.8	---	---	---
1-1/2	0.56 (14.2)	13.1	27.5	33.6	10.0	12.0	19.0
2	0.88 (22.2)*	38.8	46.2	58.5	15.9	15.7	17.9

* - Travel for Restricted Trim 0.75 inch (19.1 mm)

Relationships of note: $C_1 = 39.76 \sqrt{X_T}$ $C_G = C_V C_1$ $K_M = F_L^2$

Table 14

Valve Body and Actuator Assembly Approximate Weights

Valve Size (inch)	Body Only lb (Kg)	With Fail Open Actuator Size	Assembly Weight lb (Kg)	With Fail Closed Actuator Size	Assembly Weight lb (Kg)
1	30 (14)	DFO - 1069	70 (32)	DFC - 1069	78 (26)
1-1/2	45 (20)	DFO - 1069	85 (39)	DFC - 1069	93 (42)
2	85 (39)	DFO - 2069	136 (62)	DFC - 2069	135 (61)
		DFO - 2105	167 (76)	DFC - 2105	165 (75)
		DFO - 2156	192 (87)	DFC - 2156	206 (94)

Our Commitment of Quality

Dyna-Flo is committed to continuous improvement. All efforts have been taken to maximize the accuracy of this information. Without notification, product specifications and designs may be modified at any time. The issue of this document is for information only, and does not imply suitability, a warranty, or guarantee for a specific service.



Model 363 Control Valve

Table 15

Model 363 Fail Open Actuator Maximums

6 to 30 psig signal, 35 psig supply
 Metal Seat, Single PTFE Packing
 Class IV Shut Off

Valve Size (inch)	Port Size Inch (mm)	Actuator Sizes			
		DFO - 1069	DFO - 2069	DFO - 2105	DFO - 2156
Pressure Drop Psig (kPag)					
1	1/4 (6.4)	1,500 (10,342) ¹	N/A	N/A	N/A
	3/8 (9.5)	1,500 (10,342) ²	N/A	N/A	N/A
	1/2 (12.7)	1,500 (10,342) ²	N/A	N/A	N/A
	3/4 (19.1)	1,500 (10,342) ³	N/A	N/A	N/A
	1 (25.4)	1,440 (9,928) ⁴	N/A	N/A	N/A
1-1/2	1/4 (6.4)	1,500 (10,342) ¹	N/A	N/A	N/A
	3/8 (9.5)	1,500 (10,342) ¹	N/A	N/A	N/A
	1/2 (12.7)	1,500 (10,342) ¹	N/A	N/A	N/A
	3/4 (19.1)	1,500 (10,342) ¹	N/A	N/A	N/A
	1 (25.4)	1,440 (9,928) ⁴	N/A	N/A	N/A
	1 1/2 (38.1)	613 (4,226) ⁴	N/A	N/A	N/A
2	1/4 (6.4)	N/A	1,500 (10,342) ¹	N/A	N/A
	3/8 (9.5)	N/A	1,500 (10,342) ²	N/A	N/A
	1/2 (12.7)	N/A	1,500 (10,342) ²	N/A	N/A
	3/4 (19.1)	N/A	1,500 (10,342) ³	N/A	N/A
	1 (24.4)	N/A	750 (5,171) ³	1,500 (10,342) ⁵	N/A
	2 (50.8)	N/A	290 (1,999) ⁶	N/A	845 (5,826) ⁴

Bench Set	Psig (kPag)
1	6-30 (41-207)
2	6-26 (41-179)
3	6-20 (41-138)
4	6-14 (41-97)
5	6-18 (41-124)
6	6-15 (41-103)

Please contact Dyna-Flo for higher shut off class, PTFE seating, or graphite packing.



Model 363 Control Valve

Table 16

Model 363 Fail Close Actuator Maximums

6 to 30 Psig signal, 35 Psig supply
 Metal Seat, Single PTFE Packing
 Class IV Shut Off

Valve Size (inch)	Port Size Inch (mm)	Actuator Sizes			
		DFC - 1069	DFC - 2069	DFC - 2105	DFC - 2156
Pressure Drop Psig (kPag)					
1	1/4 (6.4)	1,500 (10,342) ¹	N/A	N/A	N/A
	3/8 (9.5)	1,500 (10,342) ¹	N/A	N/A	N/A
	1/2 (12.7)	1,500 (10,342) ¹	N/A	N/A	N/A
	3/4 (19.1)	1,500 (10,342) ²	N/A	N/A	N/A
	1 (25.4)	1,328 (9,156) ³	N/A	N/A	N/A
1 1/2	1/4 (6.4)	1,500 (10,342) ¹	N/A	N/A	N/A
	3/8 (9.5)	1,500 (10,342) ¹	N/A	N/A	N/A
	1/2 (12.7)	1,500 (10,342) ¹	N/A	N/A	N/A
	3/4 (19.1)	1,500 (10,342) ²	N/A	N/A	N/A
	1 (25.4)	1,328 (9,156) ³	N/A	N/A	N/A
	1 1/2 (38.1)	552 (3,806) ³	N/A	N/A	N/A
2	1/4 (6.4)	N/A	1,500 (10,342) ¹	N/A	N/A
	3/8 (9.5)	N/A	1,500 (10,342) ¹	N/A	N/A
	1/2 (12.7)	N/A	1,500 (10,342) ¹	N/A	N/A
	3/4 (19.1)	N/A	1,500 (10,342) ³	N/A	N/A
	1 (25.4)	N/A	750 (5,171) ³	1,500 (10,342) ³	N/A
	2 (50.8)	N/A	N/A	290 (1,999) ⁵	642 (4,426) ⁴

Bench Set

Psig (kPag)

- 1 6-30 (41-207)
- 2 18-30 (124-207)
- 3 14-30 (97-207)
- 4 15-30 (103-207)
- 5 12-30 (82-207)

Please contact Dyna-Flo for higher shut off class, PTFE seating, or graphite packing.



Model 363 Control Valve

Ordering Guide

Dyna-Flo Model 363 Control Valve | Model Numbering System

Sample Part Number

363 - 2AFL - 021P2 - ES4 - O

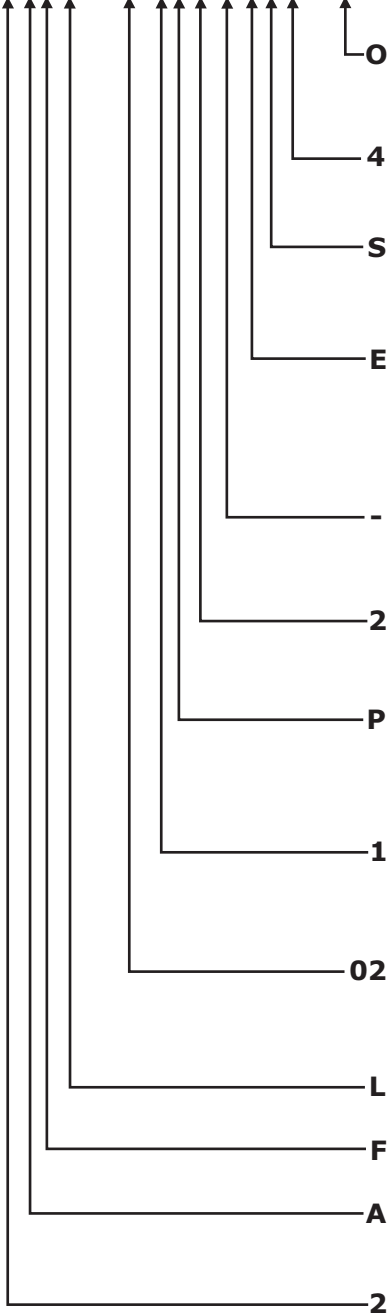

Code	Description
O	Cleaned and Package for O ₂ service
Shut-off Class	
4	Class IV - Standard Metal Seat
5	Class V - Optional Metal Seat
Bonnet Style	
S	Standard
B	Bellows
E	Extension
X	Special
Characteristic	
E	Equal Percentage
Q	Quick Open
M	Dyna-Form
D	Dyna-Flat
L	Linear
F	3 Flute Dyna-Flute
G	1 Flute Dyna-Flute
X	Special
Bolting	
-	B7 / 2H
B	B8M / 8M
A	B7M / 2HM
C	17-4 DH 1150
Valve Mounting Connection	
1	2-1/8" (3/8" stem)
3	3-9/16" (3/4" stem)
2	2-13/16" (1/2" stem)
Packing Style	
P	Spring Loaded PTFE V-ring
G	Graphite High Temp
M	Live Loaded (Graphite)
J	Jam Style PTFE V-ring
L	Live Loaded (PTFE)
Trim Number	
1	Z1
2	Z2
3	Z3
4	Z4
5	Z5
Port Size	
01	3/16"
04	1/2"
12	1-1/2"
02	1/4"
06	3/4"
16	2"
03	3/8"
08	1"
Body Material	
L	LCC
W	WCC
M	CF8M
Connection Style	
F	RF
J	RTJ
N	NPT
ASME Rating	
A	150
B	300
C	600
Valve Size	
1	1 inch
2	2 inch
5	1-1/2 inch



Technical Sales Bulletin October 2008 P-363B1008A

Model 363 Control Valve